



Request for Sealed Quotations Of Goods

Supply and Delivery of Hot Dipped Galvanized 600NB distance piece with 600NB angle Tee and crotch plates for the Swakopmund-Rossing Booster 2 outlet

Procurement Reference No: G/RFQ/NW-043/2024

Name of Bidder		
Contact Person		
E-mail Address		
Postal Address		
Total Amount (Excl. VAT)		Discount %
Contact Phone number	Work:	Mobile:

Documents must be posted / delivered to:

The Quotation/Bid Box

Att: Procurement Management Unit (+264 61 71 2009, bids@namwater.com.na)

Namibia Water Corporation Ltd.

Private Bag 13389

176 Iscor Street, Aigams Building

Windhoek

Closing Date: Thursday, 03 October 2024 at 11h00

NO LATE BIDS WILL BE ACCEPTED!

NOTICE TO BIDDERS

- Please take note of initializing all pages of the standard bidding document and initial all the supporting documents including company profiles, brochures, etc.**
- Take note to sign all relevant pages as stipulated in the bidding standard document.**
- Copies of documents not certified by a Commissioner of Oath appointed in terms of the Justices of the Peace and Commissioners of Oaths Act.1963 (Act No. 16 of 1963) will not be accepted**



Namibia Water Corporation Ltd.
Private Bag 13389, Windhoek, Namibia
Tel: +264 61 71 2066
Fax: +264 61 21 0741

Letter of Invitation

[Name and Address of Bidder _____]

Procurement Reference Number: G/RFQ/NW-043/2025

12 September 2024

Dear Bidder,

Supply and Delivery of Hot Dipped Galvanized 600NB distance piece with 600NB Angle Tee and crotch plates for the Swakopmund-Rossing Booster 2 outlet

NamWater invites you to submit your best quote for the items described in detail hereunder.

Any resulting contract shall be subject to the terms and conditions referred to in the document.

Queries, if any, should be addressed to Procurement Management Unit (Tel: +264 61 71 2009, E-mail: bids@namwater.com.na) Private Bag 13389 Windhoek, Namibia.

Please prepare and submit your quotation in accordance with the instructions given or inform the undersigned if you will not be submitting a quotation.

Yours faithfully,

Procurement Management Unit

PMU

1. SECTION I: INSTRUCTIONS TO BIDDERS

1. Rights of Public Entity

NamWater reserves the right:

- (a) to split the contract as per the lowest evaluated cost per item, or
- (b) to accept or reject any quotation; and
- (c) to cancel the quotation process and reject all quotations at any time prior to contract award.

2. Preparation of Bids

You are requested to quote for the items mentioned in Section III by completing, signing and returning:

- (a) The List of Goods and Price Schedule;
- (b) The Specifications and Compliance Sheet; and
- (c) Any other attachment deemed appropriate.

You are advised to carefully read the complete Request for Sealed Quotations document, including the Special Conditions of Contract in Section VII, before preparing your quotation.

The standard forms in this document may be retyped for completion but the Bidder is responsible for their accurate reproduction.

3. Validity of Bids

The offer validity period shall be **90 days** from the date of submission deadline.

4. Eligibility Criteria

To be eligible to participate in this Quotation exercise, you should:

- (a) Have a certified copy (certified by a Commissioner of Oath appointed in terms of the Justices of the Peace and Commissioners of Oaths Act.1963 (Act No. 16 of 1963)), of a full valid company Registration Document;
- (b) Have an original or a certified copy (certified by a Commissioner of Oath appointed in terms of the Justices of the Peace and Commissioners of Oaths Act.1963 (Act No. 16 of 1963)), of a valid Good Standing Tax Certificate, as certified by the Commissioner of Oath.;
- (c) have an original valid good Standing Social Security Certificate;
- (d) Have a valid certified copy (certified by a Commissioner of Oath appointed in terms of the Justices of the Peace and Commissioners of Oaths Act.1963 (Act No. 16 of 1963)), of Affirmative Action Compliance Certificate, proof from Employment Equity Commissioner that bidder is not a relevant employer, or exemption issued in terms of Section 42 of the Affirmative Action Act, 1998 or a valid certified copy of the original document, as certified by the Commissioner of Oath;

- (e) An undertaking on the part of the Bidder that the salaries and wages payable to its personnel in respect of this proposal are compliant to the relevant laws, Remuneration Order, and Award, where applicable and that it will abide to sub-clause 4.6 of the General conditions of Contract if it is awarded the contract or part thereof.
- (f) Submit signed Bid-securing Declaration.
- (g) A Bidder that is under a declaration of ineligibility by the Government of Namibia in accordance with applicable laws at the date of the deadline for bid submission or thereafter, shall be disqualified.

Bids from service providers appearing on the ineligibility lists of African Development Bank, Asian Development Bank, European Bank for Reconstruction and Development, Inter-American Development Bank Group and World Bank Group shall be rejected.

Links for checking the ineligibility lists are available at:

- Republic of Namibia, Procurement Policy Unit
<https://egp2.gov.na/forms/SearchSuspendedBidders.jsf>
- African Development Bank
<https://www.afdb.org/en/projects-operations/debarment-and-sanctions-procedures>
- Asian Development Bank
<http://lnadbg4.adb.org/oga0009p.nsf/sancALLPublic?OpenView&count=999>
- European Bank for Reconstruction and Development
<http://www.ebrd.com/pages/about/integrity/list.shtml>
- Inter-American Development Bank Group
<http://www.iadb.org/en/topics/transparency/integrity-at-the-idb-group/sanctioned-firms-and-individuals,1293.html>
- World Bank Group
<http://www.worldbank.org/en/projects-operations/procurement/debarred-firms>

5. Bid Securing Declaration

Bidders are required to subscribe to a Bid Securing Declaration for this procurement process.

6. Delivery

Delivery shall be **6-10 weeks** after acceptance/issue of Purchase Order. Deviation in delivery period shall not be accepted.

7. Sealing and Marking of Bids

Quotations should be sealed in a single envelope, clearly marked with the Procurement Reference Number, addressed to NamWater with the Bidder's name and contact information at the back of the envelope.

8. Submission of Bids

Quotations should be deposited in the Quotation/Bid Box located at Namibia Water Corporation Ltd Head office, Private Bag 13389, 176 Iscor Street, Aigams Building, Windhoek, not later than **03 October 2024 at 11h00**. Offers by post or hand delivered should reach Private Bag 13389 by the same date and time at latest. Late Offers will be rejected.

Quotations received by e-mail will not be considered.

9. Opening of Bids

Bids will be opened internally by NamWater representatives immediately after the closing time referred to in instruction 8 above. A record of the Quotation Opening stating the name of the bidders, the amount quoted, the presence or absence of a Bid Securing Declaration, will be posted on the website of NamWater and available to any bidder on request within three working days of the Opening.

10. Evaluation of Bids

NamWater shall have the right to request for clarifications in writing during evaluation. Offers that are substantially responsive shall be compared on the basis of price or ownership cost, subject to Margin of Preference where applicable, to determine the lowest evaluated quotation.

11. Technical Compliance

Bidders shall submit along with their quotations documents, catalogues and any other literature to substantiate compliance with the required specifications and to qualify deviations if any with respect to NamWater's requirements. A method statement should be accompanying the document on the installation and maintenance procedure.

The Specifications, Performance Requirements and Compliance Sheet details the minimum specifications of the goods/items to be supplied. The specifications have to be met but no credit will be given for exceeding the specifications.

12. Prices and Currency of Payment

Prices shall be fixed in Namibian Dollars.

13. Margin of Preference

Not Applicable

14. Award of Contract

The Bidder having submitted the lowest evaluated responsive quotation and qualified to supply the goods/items and related services shall be selected for award of contract. Award of contract shall be by issue of a Purchase Order/Letter of Acceptance in accordance with terms and conditions contained in Section VI: Contract Agreement and General Conditions of Contract.

No Partial award. Offers that only quote for some of the items will not be considered.

15. Notification of Award and Debriefing

NamWater shall after award of contract promptly inform all unsuccessful bidders in writing of the name and address of the successful bidder and the contract amount and post a notice of award on its website within seven (7) days. Furthermore, NamWater shall attend to all requests for debriefing made in writing within seven (7) days of the unsuccessful bidders being informed of the award.

SECTION II: QUOTATION LETTER

(to be completed by Bidders)

[Complete this form with all the requested details and submit it as the first page of your quotation with the Price list and documents requested above. A signature and authorisation on this form will confirm that the terms and conditions of the RFQ prevail over any attachments. **If your quotation is not authorised, it will be rejected.**]

Quotation addressed to:	NamWater
Procurement Reference Number:	G/RFQ/NW-043/2025
Subject matter of Procurement:	Supply and Delivery of Hot Dipped Galvanized 600NB distance piece with 600NB angle Tee and crotch plates for the Swakopmund-Rossing Booster 2 outlet

We offer to supply the items listed in the attached List of Goods and Price Schedule as per the defined specifications, except for the qualified deviations [Bidder may delete this phrase in case of no deviation] and, in accordance with the terms and conditions stated in your Request for Quotations referenced above.

We confirm that we are eligible to participate in this Quotation exercise and meet the eligibility criteria specified in Section 1: Instruction to Bidders.

We undertake to abide ethical conduct during the procurement process and the execution of any resulting contract.

We have read and understood the content of the Bid Securing Declaration (BSD) attached hereto and subscribe fully to the terms and conditions contained therein. We further understand that this subscription could lead to disqualification on the grounds mentioned in the BSD.

The validity period of the Quotation is **days** from the date of the bid submission deadline.

We confirm that the prices quoted in the List of Goods and Price Schedule are fixed and firm and will not be subject to revision or variation, if we are awarded the contract **prior to the expiry** date of the quotation validity.

The delivery period offered from the date of issue of Purchaser Order/ Letter of Acceptance is as shown in the List of Goods items and Price Schedule.

Quotation Authorised by:

Name of Bidder		Company's Address and seal	
Contact Person			
Name of Person Authorising the Quotation:	Position:	Signature:	
Date		Phone No./Fax	

BID SECURING DECLARATION
(Section 45 of Act)
(Regulation 37(1)(b) and 37(5))

Date: [Day|month|year]

Procurement Ref No.:

To: Namibia Water Corporation Ltd., 176 Iscor Street, Ai-//gams Building, Windhoek

I/We* understand that in terms of section 45 of the Act a public entity must include in the bidding document the requirement for a declaration as an alternative form of bid security.

I/We* accept that under section 45 of the Act, I/we* may be suspended or disqualified in the event of

- a) **a modification or withdrawal of a bid after the deadline for submission of bids during the period of validity;**
- b) **refusal by a bidder to accept a correction of an error appearing on the face of a bid;**
- c) **failure to sign a procurement contract in accordance with the terms and conditions set forth in the bidding document, should I/We* be successful bidder; or**
- d) **Failure to provide security for the performance of the procurement contract if required to do so by the bidding document.**

I/We* understand this bid securing declaration ceases to be valid if I am/We are* not the successful Bidder

Signed:
[insert signature of person whose name and capacity are shown]

Capacity of:
[indicate legal capacity of person(s) signing the Bid Securing Declaration]

Name:
[insert complete name of person signing the Bid Securing Declaration]

Duly authorized to sign the bid for and on behalf of: [insert complete name of Bidder]

Dated on _____ day of _____, _____
[insert date of signing]

Corporate Seal (where appropriate)

[Note: In case of a joint venture, the bid securing declaration must be in the name of all partners to the joint venture that submits the bid.]*



Republic of Namibia

Ministry of Labour, Industrial Relations and Employment Creation

Written undertaking in terms of section 138 of the Labour Act, 2015 and section 50(2)(D) of the Public Procurement Act, 2015

1. EMPLOYERS DETAILS

Company Trade Name:.....

Registration Number :.....

Vat Number:

Industry/Sector:

Place of business:.....

Physical address:.....

Tell no.:.....

Fax no.:.....

Email address:.....

Postal address:.....

Full name of Owner/Accounting officer:.....

.....

Email address:.....

2. PROCUREMENT DETAILS

Procurement Reference No.:.....

Procurement Description:

.....

.....

Anticipated Contract Duration:

Location where work will be done, good/services will be delivered:

.....

3. UNDERTAKING

I [insert full name], owner/representative
of [insert full name of company]

hereby undertake in writing that my company will at all relevant times comply fully with the relevant provisions of the Labour Act and the Terms and Conditions of Collective Agreements as applicable.

I am fully aware that failure to abide to such shall lead to the action as stipulated in section 138 of the labour Act, 2007, which include but not limited to the cancellation of the contract/licence/grant/permit or concession.

Signature:

Date:

Seal.....

Please take note:

1. A labour inspector may conduct unannounced inspections to assess the level of compliance
2. This undertaking must be displayed at the workplace where it will be readily accessible and visible by the employees rendering service(s) in relations to the goods and services being procured under this contract.

SECTION IV: SPECIFICATIONS AND PERFORMANCE REQUIREMENTS

GENERAL DESCRIPTION AND BACKGROUND

This tender calls for the Supply and Delivery of Hot Dipped Galvanized 600NB distance piece with 600NB angle Tee and crotch plates for the Swakopmund-Rossing Booster 2 outlet. This specification covers the design, manufacture and supply of Hot Dipped Galvanized pipes. This specification is a supplement to the relevant SANS specifications and will in no way relieve the bidders of the requirements of the relevant SANS specifications.

STEEL PIPE DESIGN

The distance piece flanges shall conform to SANS 1123/2500/3.

Unless otherwise specified distance piece shall be rated S.A.B.S / SANS 719 Grade B.

The coating shall be Hot Dip Galvanized to S.A.B.S ISO 1461:1999.

The crotches shall be 30mm thick as per drawing

Note: The average galvanizing layer thickness shall not be less than 150 micron and the minimum thickness at any spot less than 100 micron.

The wall thickness of the distance piece is 6mm as indicated in this document is a minimum thickness.

TABLE 1: 25 BAR STEEL PIPE COMPLETE WITH CROTCHES

NOMINAL DIAMETER	OUTER DIAMETER	WALL THICKNESS
600mm	611.20mm	6.0mm

PRESSURE TESTING

The distance piece shall be guaranteed for a test pressure of 1.5x rated pressure.

A guarantee pressure certificate shall be supplied with the items. Delivery will only be considered complete when all items and test certificates have been delivered.

TRANSPORTATION

Note: The distance piece shall at all times be transported and handled in such a manner as to guard against circumferential and radial distortion or damage. The supplier should ensure that during loading, transportation and delivery of the distance piece it is not distorted in any way, more specifically the circular profile structure of two plain ends.

SECTION V: SPECIFICATIONS AND COMPLIANCE SHEET

Item No	Technical Specification Required	Compliance Specification Offered	of	Details of Non-Compliance/ Deviation (if applicable)
<i>A*</i>	<i>B*</i>	<i>C</i>		<i>D</i>
1.0	General Information			
	Country of Manufacture			
	Distance piece flanges shall conform to SANS 1123/2500/3	(Yes / No)		
	All Steel Pipes are guaranteed for a Test Pressure of 1.5x rated pressure	(Yes / No)		
	Hot Dip Galvanized to S.A.B.S ISO 1461:1999.	(Yes / No)		
	Crotches 30mm thick as per drawing	(Yes / No)		
	Pipe wall thickness 6mm	(Yes / No)		
	Pressure Test Certificates Supplied:	(Yes / No)		
2.0	Specifications			
2.1	Dimensions			
	Nominal Bore (mm)			
	Outer Diameter (mm)			
	Wall thickness (mm)			
	Distance piece Length (mm)			
	Operating Pressure (Bar)			
	Test Pressure (Bar)			
	Pipe Weight in kg/meter			
2.2	Coating			
	All Steel Pipes Sand Blasted & Hot Dip Galvanized to SABS ISO 1461:1999 ?	(Yes / No)		

	Galvanizing Average thickness (micron)		
3.0	Warranty Period	(Yes / No)	
	Warranty conditions		

Specifications and Compliance Sheet Authorised By:

Name:		Signature:	
Position:		Date:	
Authorised for and on behalf of:		Company	

SECTION VI: GENERAL CONDITIONS OF CONTRACT AND CONTRACT AGREEMENT

Any resulting contract shall be placed by means of a Purchase Order/Letter of Acceptance and shall be subject to the General Conditions of Contract (GCC) for the Procurement of Goods (Ref. **G/RFQ-GCC**) www.namwater.com.na except where modified by the Special Conditions below.

SECTION VI: CONTRACT AGREEMENT

Any resulting contract shall be placed by means of a Purchase Order/Letter of Acceptance and shall be subject to the General Conditions of Contract (GCC) for the Procurement of Goods except where modified by the Special Conditions below.

SECTION VII: SPECIAL CONDITIONS OF CONTRACT

Procurement Reference Number: G/RFQ/NW-043/2025

The clause numbers given in the first column correspond to the relevant clause number of the GCC.

Subject and GCC clause reference	Special Conditions
Site GCC 1.1(m)	The Site/final destination for delivery of the Goods is NamWater Stores, Swakopmund
Incoterms Edition GCC 4.2(b)	Incoterms shall be governed by the rules prescribed in Incoterms 2010.

Subject and GCC clause reference	Special Conditions
Notices GCC 8.1	Any notice shall be sent to the following addresses: For NamWater, the address and the contact name shall be: The Accounting Officer E-mail: <u>bids@namwater.com.na</u> Private Bag 13389 Windhoek, Namibia. For the Supplier, the address and contact name shall be: _____
Disputes GCC 10.2	The rules of procedures for arbitration proceedings pursuant to GCC 10.2 shall be as follows: In the case of a dispute between the Purchaser and a Supplier who is a national of Namibia, the dispute shall be referred to adjudication or arbitration in accordance with the laws of Namibia.
Delivery and Documents GCC 13.1	The Goods are to be delivered 6-10 weeks from the date of Purchase Order or Letter of Acceptance. The documents to be furnished by the Supplier are: (a) signed delivery note (b) Invoice
Price Adjustment GCC 15.1	The price charge for the Goods supplied and the related Services performed shall not be adjustable.
Terms of Payment GCC 16.1	The structure of payments shall be: full payment following delivery of the Supplies and submission of an invoice and the documents listed in clause 13.1
Terms of Payment GCC 16.3	NamWater shall make payments not later than thirty days after submission of an invoice and its certification.
Terms of Payment GCC 16.4	The price shall not be adjustable to the fluctuation in the rate of exchange.

Subject and GCC clause reference	Special Conditions
Payment Period GCC 16.5	<p>The method and conditions of payments to be made to the Supplier under this Contract shall be as follows:</p> <p>i) On Acceptance: The Contract Price of goods received shall be paid no later than thirty (30) days of receipt of the Goods upon submission of an invoice (showing Purchaser's name; the Procurement Reference number, description of payment and total amount, signed in original, stamped or sealed with the company stamp/seal) supported by the Acceptance Certificate issued by the Purchaser.</p>
Performance Security GCC 18.1	(i) No performance security is required
Packing GCC 23.2	<p>The packing, marking and documentation within and outside the packages shall be:</p> <p>G/RFQ/NW-043/2025</p> <p>Supply and Delivery of Hot Dipped Galvanized 600NB distance piece with 600NB angle Tee and crotch plates for the Swakopmund-Rossing Booster 2 outlet.</p> <p>NamWater Swakopmund</p>
Transportation GCC 25	The Goods shall be delivered: DDP – Delivered Duty Paid
Inspection and Test GCC 26.1	The inspection and tests shall be: On Delivery at the NamWater Stores, Swakopmund
Liquidated Damages GCC 27.1	Liquidated damages for the whole contract are 0.5% per day. The maximum amount of liquidated damages for the whole contract is 10% of the final contract price.
Warranty GCC 28.3	The period of validity of the warranty shall be: 12 month for all the parts supplied

Subject and GCC clause reference	Special Conditions
Repair and Replacement GCC 28.5	The period for repair or replacement shall be: 30 day(s)

SCHEDULE 3 :**Quotation Checklist Schedule****Procurement Reference No.: G/RFQ/NW-043/2025**

Description	Attached	Not Attached
Quotation Letter		
List of Goods and Price Schedule		
Specification and Compliance Sheet		
Bid Securing Declaration		
Evidences for conformity of Goods		
Valid Company Registration from Ministry of Trade and Industry or BIPA , a valid certified copy of an original certified by the Namibian Police or Commissioner of Oath.		
Original valid good standing Tax Certificate from Inland Revenue or a valid certified copy of an original certified by the Namibian Police or Commissioner of Oath.		
Original valid good Standing Certificate from Social Security Commission or a valid certified copy of an original certified by the Namibian Police or Commissioner of Oath.		
Valid Affirmative Action Compliance Certificate, proof from Employment Equity Commissioner that bidder is not a relevant employer, or exemption issued in terms of Section 42 of the Affirmative Action Act, 1998; a valid certified copy of an original certified by the Namibian Police or Commissioner of Oath.		

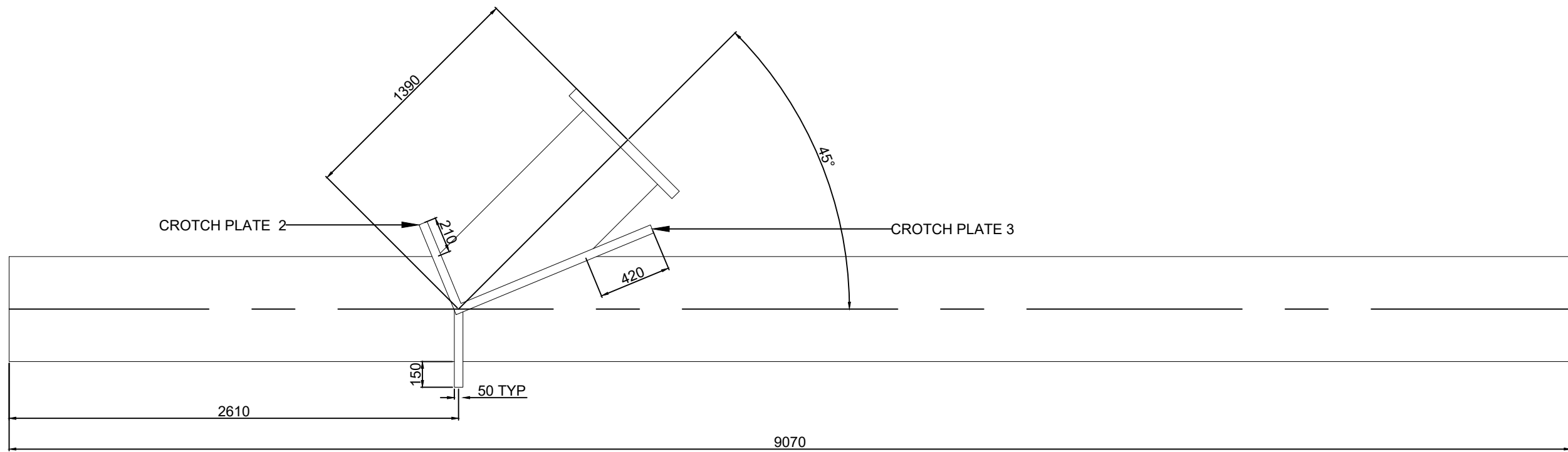
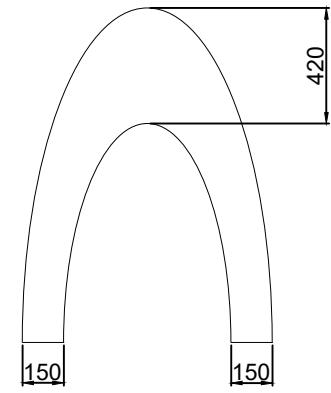
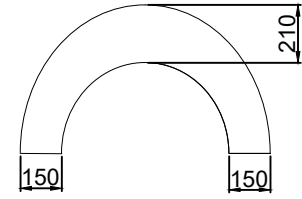
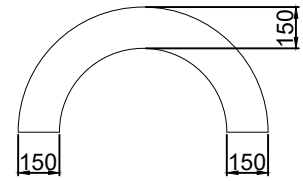

600NB DISTANCE PIECE WITH 600NB
 ANGLED TEE AND CROTCH PLATE
 6MM WALL THICKNESS
 SANS 1123/2500/3



Our Ref.:
G/RFQ/NW-
043/2025

Your Ref.:

Enquiries: Puje Katjivena

Telephone: +264 61 71 2819
E-mail: Bids@namwater.com.na

20 September 2024

NOTICE TO BIDDERS – NO 1

PROCUREMENT REFERENCE NUMBER: G/RFQ/NW-⁴³043/2025

Supply and Delivery of Hot Dipped Galvanized 600NB distance piece with 600NB angle Tee and crotch plates for the Swakopmund-Rossing Booster 2 outlet

Dear Bidders,

In accordance with Instruction to Bidders 8 (**Clarification of bidding Documents**) and 9 (**Amendment of Bidding Documents**) of the Bidding Document the Employer will respond in writing to any request for clarification, and should the Employer deem it necessary to amend the Bidding Document as a result of a request for clarification, it shall do so.

This notice to bidders form an integral part of the bidding documents and must be attached to the offer upon submission.

1. QUERIES

Technical enquiries on Annexure 1

Yours sincerely,

Ms. Puje Katjivena
HEAD: SUPPLY CHAIN MANAGEMENT

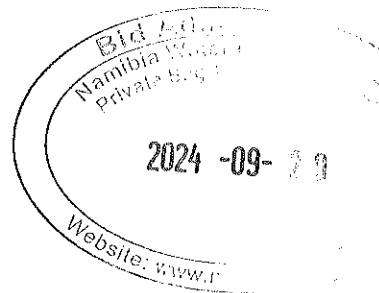



Date: Friday, September 20, 2024

NOTICE TO BIDDERS - NO 1

PROCUREMENT REFERENCE NUMBER: G/RFQ/NW-043/2025

Supply and Delivery of Hot Dipped Galvanized 600NB distance piece with 600NB angle Tee and crotch plates for the Swakopmund-Rossing Booster 2 outlet

ACKNOWLEDGEMENT OF RECEIPT

CONFIRMATION

I, of

Hereby confirm receipt of the Notice to Bidders – No 1

Signed at On this Day

.....
On behalf of the Bidder

ANNEXURE 1- CLARIFICATION REQUEST

CLARIFICATION REQUEST		
QUESTION NO	BIDDER QUESTION	NAMWATER RESPONSE
1.	<p>I am hereby would like to request for more information about the Hot Dipped Galvanized 600NB Distance Piece with 600NB Angle Tee and Crotch Plates.</p> <p>1. Can you please provide us with the Isometric drawing?</p>	<p>Unfortunately no isometric drawing is available. The workshop fabricating the T-piece should not have any difficulty interpreting the attached standard drawing (attached on the bid document). Below is an illustration of almost similar arrangement, only that the required one does not have curved crotch plates plus there is a third plate opposite the branch intersection.</p>